

Qubit-in-a-box 2 (QiB2)

v 1.0, 24 November 2025

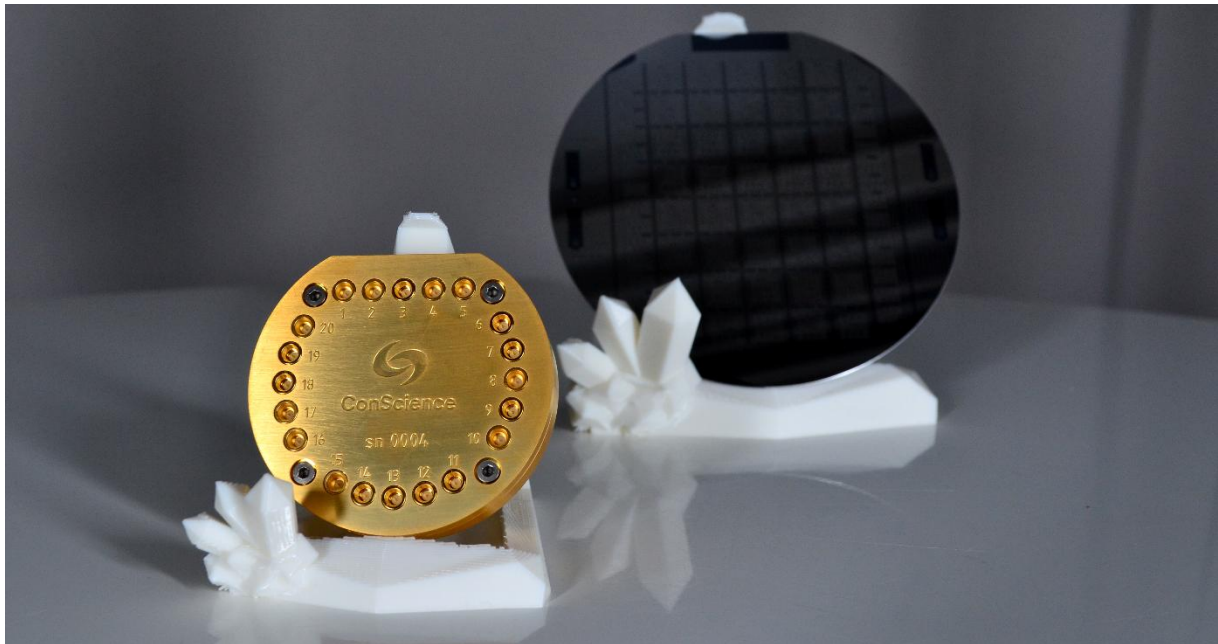

Overview

The QiB2 is a versatile device - ideal for validating cryogenic microwave measurement environments, investigating different superconducting quantum processor structures with various coupling architectures, and for supporting education through hands-on training in quantum technologies.

The device features two pairs of coupled qubits:

- a tunable qubit pair with a fixed coupler
- a fixed-frequency qubit pair with a tunable coupler

Perfect for studying the different families of two-qubit gates enabled by these coupling architectures!

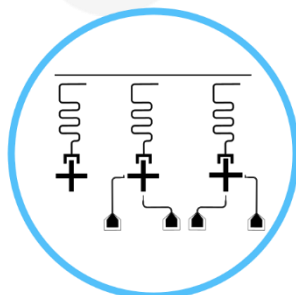
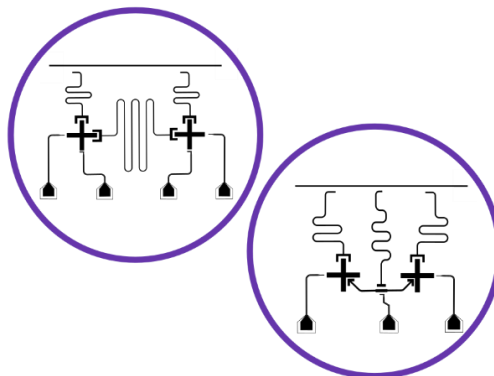

Additionally, the device features standard measurement setup calibration points with increasing levels of complexity: starting from bare resonators, through a single fixed-frequency qubit, up to two single frequency-tunable qubits with different levels of flux sensitivity.

The device comes conveniently mounted in our Box20 package connectorized with high-density SMPM connectors. The SMPM connectors may be interfaced with SMA via adaptor cables.

Product features

The QiB2 features a total of **7 qubits** in the following configuration:

- 2 tunable qubits coupled through a fixed coupler
- 2 fixed-frequency qubits coupled through a tunable coupler
- 3 single qubits with different levels of complexity:
 - 1 fixed-frequency qubit coupled only to its resonator
 - 2 tunable qubits with dedicated drive and flux lines, with varying magnetic flux sensitivity

The device also features **10 resonators** coupled to a shared input-output transmission line:

- A dedicated readout resonator for each of the 7 qubits
- A dedicated resonator for the tunable coupler state readout
- 2 bare coplanar waveguide resonators

The equivalent schematic below shows the various elements on the QiB2 and their interconnectivity. Qubits are marked with Q, couplers with C, and bare resonators with BR:

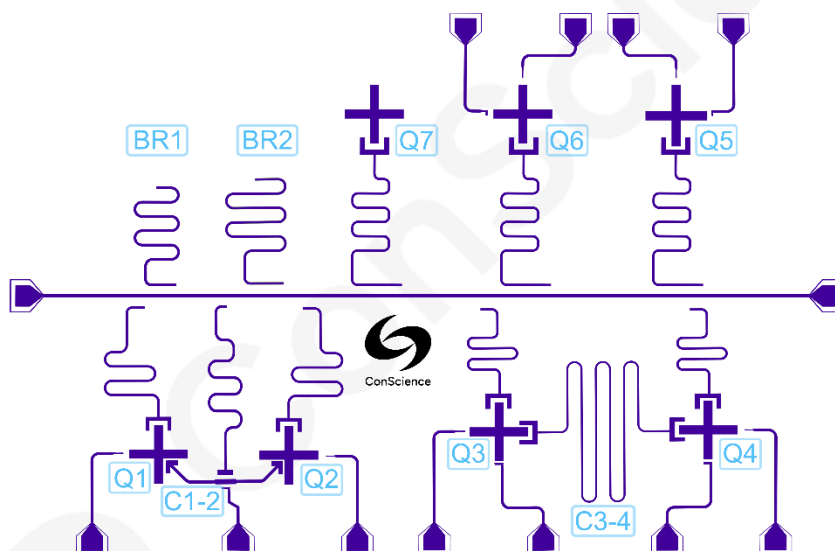

Highlights	
Qubit frequencies	3—5.5 GHz
Resonator and coupler frequencies	4.5—8GHz
Two-qubit gate frequencies	<2GHz
Single-qubit T_1	Up to 140 μ s on average and up to 223 μ s as highest
Spin-echo T_2^{echo}	1—2 $\times T_1$
Bare resonator Q_i	$\gtrsim 1 \times 10^6$ at single-photon power levels and mK temperatures

The chip comes mounted and wire-bonded to a gold-plated oxygen-free high thermal conductivity copper (gold-plated OFHC) sample box, connectorized with high-density SMPM connectors.

Design parameters - QiB2

The following table shows the design parameters for the frequencies of the qubits f_q , as well as the frequencies of their respective readout resonators, the bare resonators, and couplers, f_r .

Qubits 1 and 2 are paired fixed-frequency qubits coupled through the tunable Coupler 1-2.

Qubits 3 and 4 are paired frequency-tunable qubits coupled through a fixed Coupler 3-4.

Qubits 5-7 are single qubits – one fixed-frequency qubit driven through its readout resonator (Q7), and two tunable qubits with dedicated charge and flux lines (Q5, Q6).

QiB2 design parameters				
	Frequency variability	Coupling	f_q (GHz)	f_r (GHz)
Qubit 1	Fixed	Coupled	4.01	6.20†
Qubit 2	Fixed	Coupled	4.85	7.04†
Coupler 1-2	Tunable	–	6.1	7.26†
Qubit 3	Tunable	Coupled	5.0	7.14†
Qubit 4	Tunable	Coupled	5.5	7.75†
Coupler 3-4	Fixed	–	–	4.65
Qubit 5	Tunable	Single	4.14	6.30†
Qubit 6	Tunable	Single	4.34	6.59†
Qubit 7	Fixed	Single	3.31	4.9†
Bare resonator 1	–	–	–	5.35
Bare resonator 2	–	–	–	6.78

†Dressed-state frequency

Spec sheet: QiB2

Reference device QiB2-003*

QiB2 measured characteristics			
	f_q (GHz)	f_r (GHz)	T_1 (μ s)
Qubit 1	4.08	6.30†	68
Qubit 2	4.81	7.16†	37
Coupler 1-2	5.96	7.39†	
Qubit 3	4.99	7.28†	39
Qubit 4	5.51	7.89†	22
Coupler 3-4	–	4.78	–
Qubit 5	4.27	6.43†	21
Qubit 6	4.42	6.72†	48
Qubit 7	3.45	5.01†	75
Bare resonator 1	–	5.35	
Bare resonator 2	–	6.78	

†Dressed-state frequency

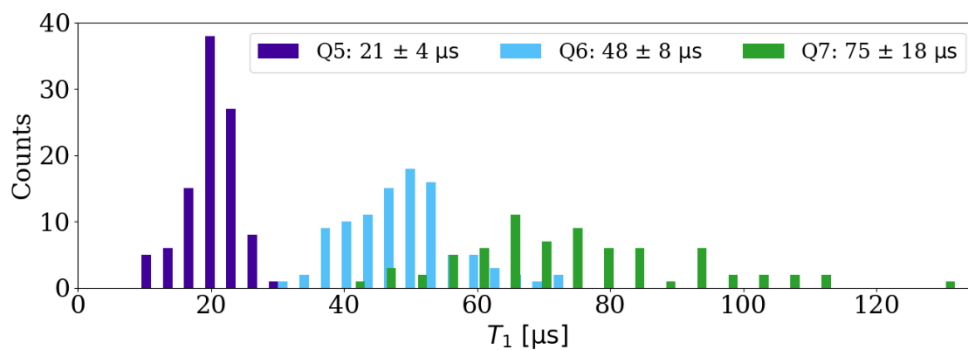
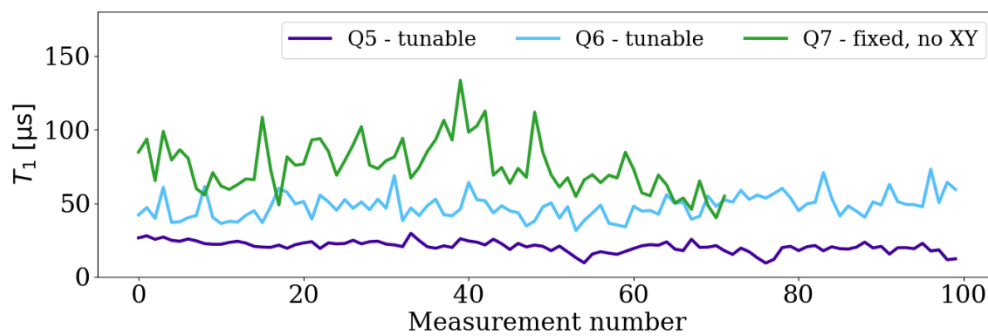

* Specific parameters for each unit are only available for individually characterized products.

Recommended measurement setup

All bare and readout resonators on the QiB2 are coupled to a shared input/output transmission line. All qubits apart from Q7 have a dedicated drive line, and all tunable elements (qubits Q3, Q4, Q5, Q6 as well as the tunable coupler C1-2) have a magnetic flux line.

We recommend the following setup for the coaxial RF lines and twisted-pair DC lines:

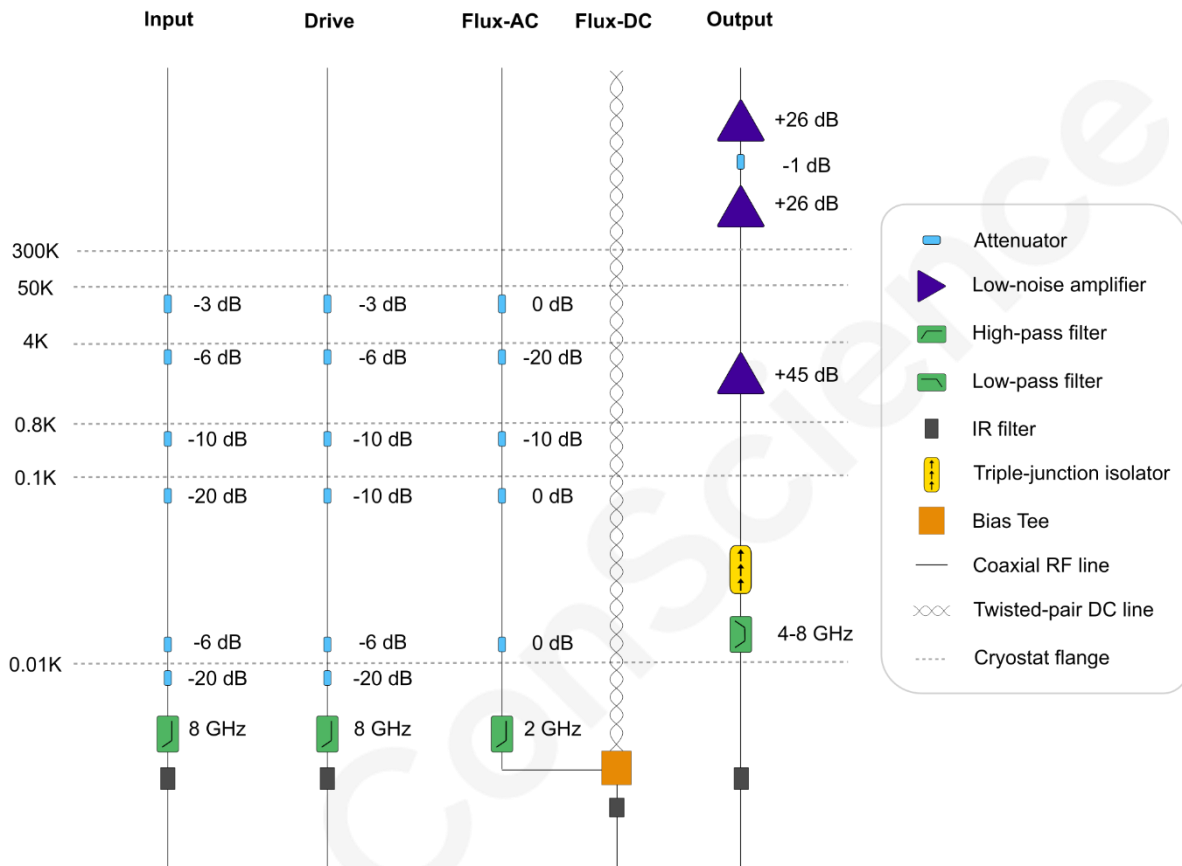

Note that for the single frequency-tunable qubits (Q5 and Q6), a DC line is sufficient for frequency tuning – the AC component is not necessary.

In the absence of appropriately connectorized DC lines, the twisted pair line may be replaced by a low-attenuation RF line with a near-DC low-pass filter at the device input. The AC and DC components of flux pulses may also be combined at room temperature and sent to the device via an RF line.

The optimal operating temperature is below 50mK for fixed-frequency elements, and around 10mK for tunable elements.

As the qubit coherence and gate fidelity are strongly impacted by environmental noise, we recommend operating the QiB2 in a dedicated sample space with additional shielding complementing the standard cryostat shielding. Recommended shielding comprises of a dedicated thermal+infrared shield enclosed in a magnetic shield.

Installation

The Box20 is equipped with 20 SMPM connectors arranged in a radial fashion. 6-inch long SMPM-to-SMA adaptor cables can be provided upon request.

1. If using SMPM-to-SMA adapter cables, start by inserting the SMPM side of each cable into the Box20 ports marked in the table below. Keep the adapter cable perpendicular to the Box20 connector and apply force until the connector clicks into place. Do not twist.
2. Mount the Box20 with M3 screws of appropriate length to the lowest temperature stage of a cryostat. The Box20 can be attached from the flat side or the back face. The depth of the threaded hole is 4mm on the flat side of the Box20, and 3mm on the back face. Assure good contact to the mounting plate for sample thermalization. The optimal operating temperature is around 10 mK.
3. Connect the tabulated Box20 ports to the appropriately configured input/output lines of the cryostat. If using SMA connectors, do not over-tighten (required torque 0.3 – 0.6 N·m).

Box20 Input/output line connection		
Port ID	Line type	Target element
1	–	–
2	Drive	Q3
3	Flux	Q3
4	Flux	Q4
5	Drive	Q4
6	–	–
7	Readout input	All
8	–	–
9	–	–
10	Readout output	All
11	Drive	Q2
12	Flux	Q1-Q2 coupler
13	–	–
14	Drive	Q1
15	–	–
16	–	–
17	Flux*	Q6
18	Drive	Q6
19	Drive	Q5
20	Flux*	Q5

*A DC line is sufficient for tuning Q5 and Q6

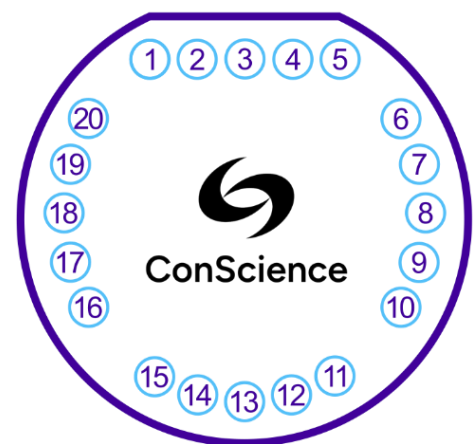

Dimensions

Units: mm

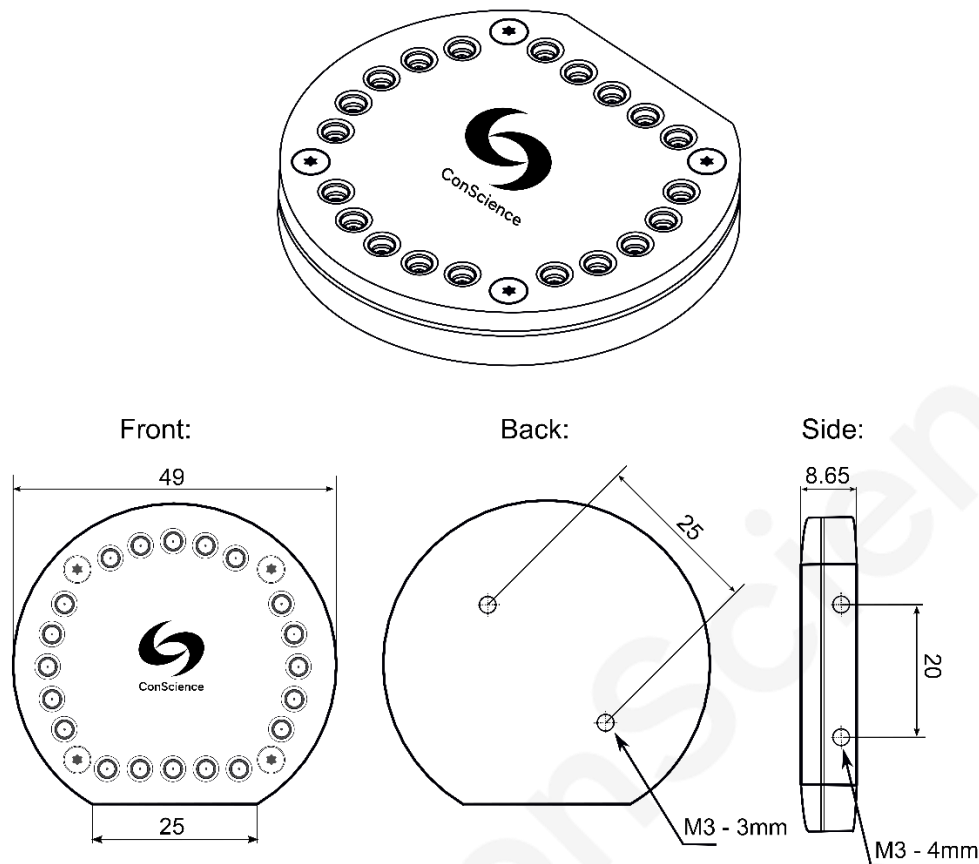

Dual-use

The device is classified as dual-use (can be used for both civilian and military applications) according to Annex 1, Category 3: Electronics, 3A001 **:

Electronic devices and circuits containing components, manufactured from "superconductive" materials, specially designed for operation at temperatures below the "critical temperature" of at least one of the "superconductive" constituents and having any of the following:

1. Current switching for digital circuits using "superconductive" gates with a product of delay time per gate (in seconds) and power dissipation per gate (in watts) of less than 10-14 J; or
2. Frequency selection at all frequencies using resonant circuits with Q-values exceeding 10 000;

** Specific export regulations may apply depending on destination country.