



www.QuantumMicrowave.com

Cryogenic Non-Magnetic SMA Shorting Cap P/N: QMC-CRYOSCAP

Specifications:

- SMA and 2.92mm Non-magnetic Male shorting cap
- Prevents RF Leakage
- Gold Plated Phosphor Bronze
- Uses 5/16 Wrench

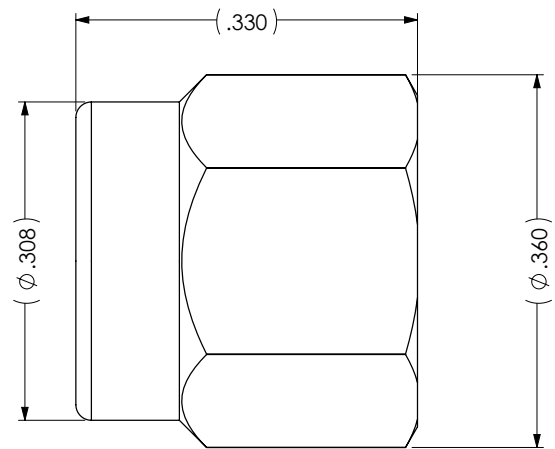
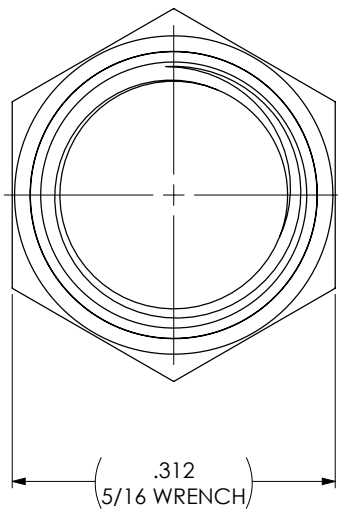

Quantum Microwave Components
Phone: 857-499-0071 Email: Sales@QuantumMicrowave.com