



www.QuantumMicrowave.com

QMC-CRYOATTF-10BLK

Thermalized Non-Magnetic Crystalline Quartz Cryogenic Attenuators

- Frequency: DC to 18 GHz
- Attenuation: 10dB
- Minimal change in attenuation with temperature
- Excellent RF Match
- Non-superconducting microstrip pad
- NiCr Crystalline Quartz conductive dielectric
- Silver Epoxy bonded
- Machined OFHC block, gold plated
- Connector 1: SMA Female short
- Connector 2: SMA Female bulkhead
- Stackable mechanical design
- 100% Non-Magnetic



Parameter	Specification	Notes
Frequency Range	DC to 18 GHz	
Attenuation Setting @5GHz	10dB +/- 0.5 dB	
Insertion Loss variation with frequency	10dB: 0.2 dB typ.	See plot
Return Loss, 10 dB atten.	-15dB typ.	See plot
Connectors	SMA (f short-f bulkhead)	
Max Power Handling	100 mW	

Measured Data (typical)

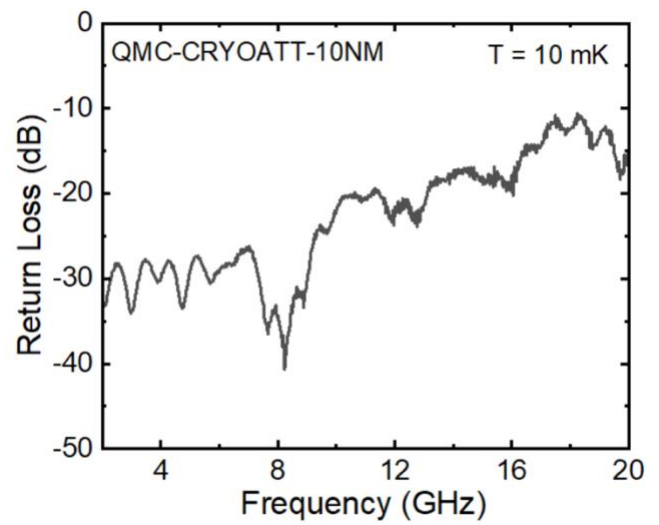
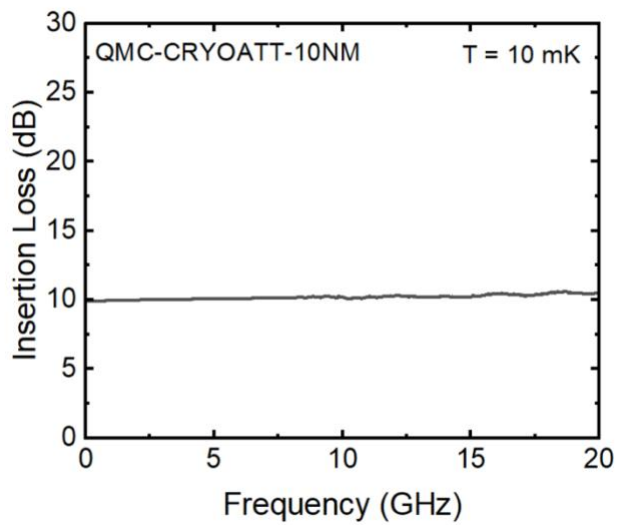
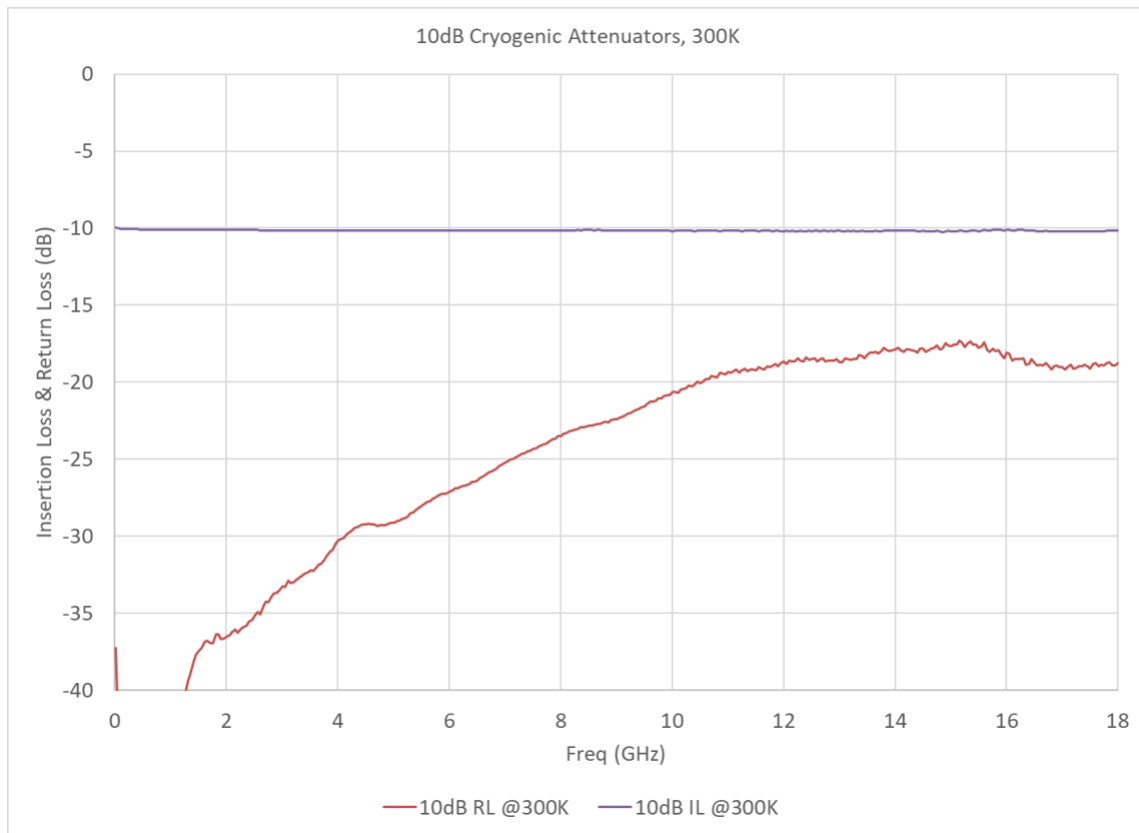

Outline Drawing [inches]

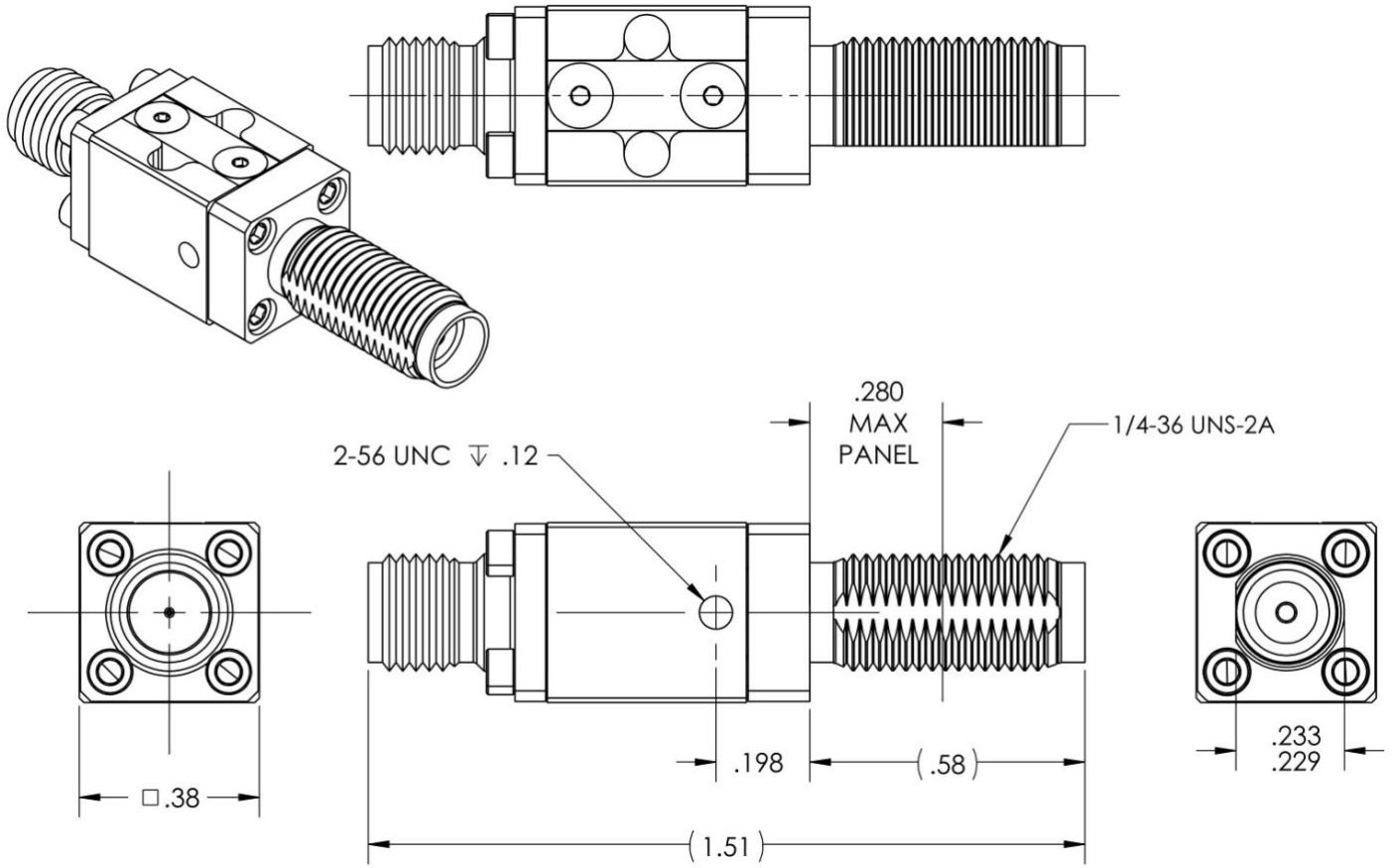

Magnetism Test information:

- Before the measurement, the devices are put in proximity (below 1cm) to a magnet for about 5 seconds, to induce magnetization of eventual magnetic material.
- The magnetic field is measured over the surface of the device and along different axis. The distance between probe and device is below 1cm. The values reported in the picture is the maximum detected.
- All the measurements are in Gauss [Gs]
- The measurements have been done with a TD8620 magnetometer. Sensitivity is 0.1 Gs.
- The values are reported on the arrow corresponding to the direction of the magnetic field.

Part Number: QMC-CRYOATTF-10BLK

Description: 10 dB Cryogenic Non-Magnetic Attenuator

Comments: The Field of the device is below the 0.1 Gs

