

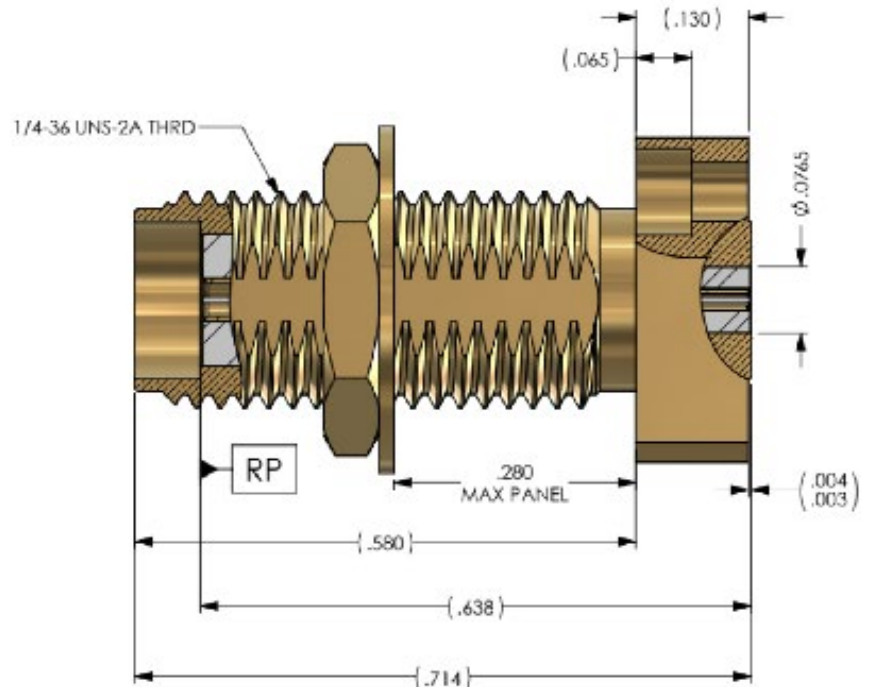

Specifications:

- Non-Magnetic Cryogenic Field Replaceable Connector
- Bulkhead SMA Female (Longer)
- Frequency Range: DC-27 GHz
- Nominal Impedance: 50 OHMS
- VSWR: 1.15:1 Max (DC-27GHz)
- Body Material: Phosphor Bronze
- Inner Pin Contact: Beryllium Copper
- Finish: Gold Plated
- Extra Long for Bulkhead Mounting
- Used in Dilution Refrigerator
- Thermalizes to Cold Plate

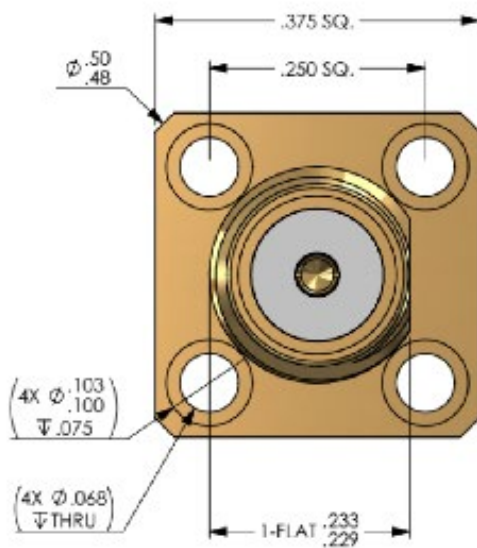
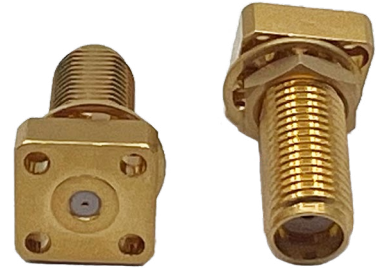

Made in the USA

✉ Sales@QuantumMicrowave.com