

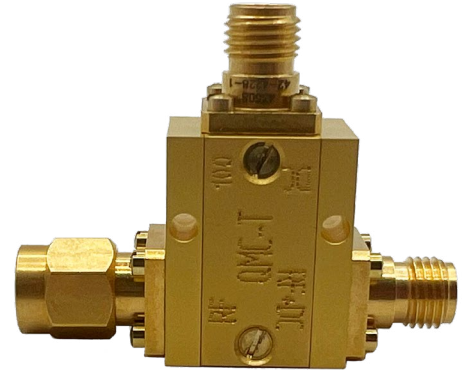

Specifications:

- Cryogenic Bias Tee
- Frequency: 0.2 to 18 GHz
- Insertion Loss: 0.25 dB from 0.2 to 12 GHz (Cold)
- Insertion Loss: 1 dB from 0.2 to 18 GHz
- Return Loss: -20 dB from 0.2 to 12 GHz
- Return Loss: -15 dB from 0.2 to 18 GHz
- Connectors: RF+DC SMA Female
- RF: SMA Male
- DC: SMA Female
- Housing Material: OFHC Copper
- Finish: Gold Plated
- Max Voltage: 35 V
- Max Current: 250 mA
- Magnetic Field is less than 0.1 Gauss



Measured Data (Typical):

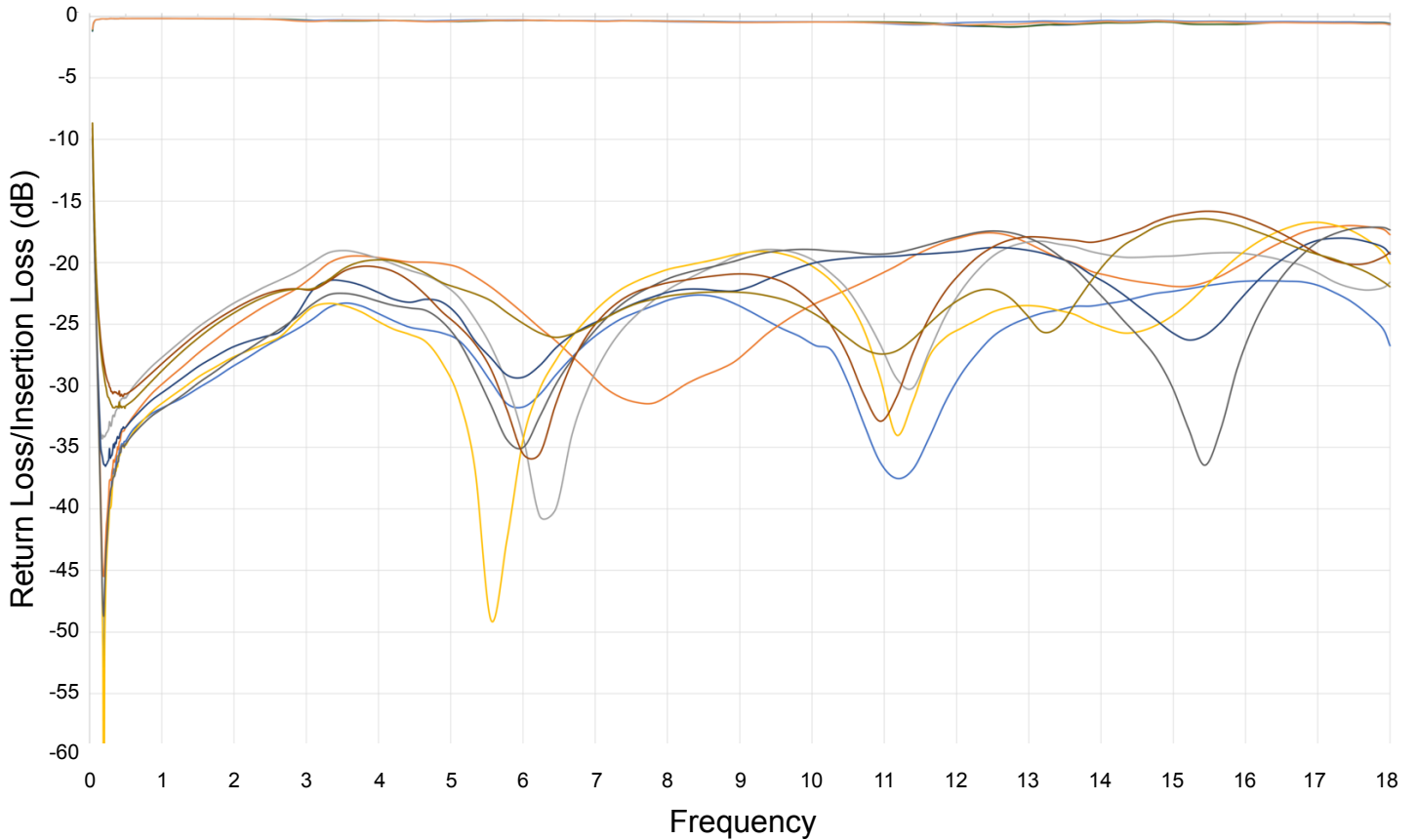

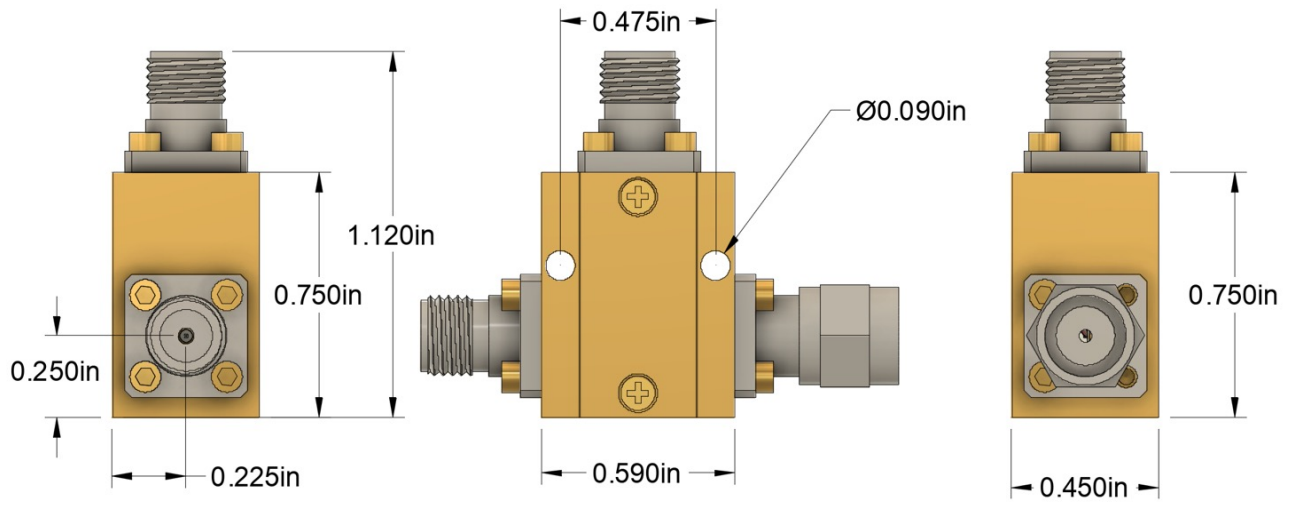

### Magnetism Test information:

- Before the measurement, the devices are put in proximity (below 1cm) to a magnet for about 5 seconds, to induce magnetization of eventual magnetic material.
- The magnetic field is measured over the surface of the device and along different axis. The distance between probe and device is below 1cm. The values reported in the picture is the maximum detected.
- All the measurements are in Gauss [Gs]
- The measurements have been done with a TD8620 magnetometer. Sensitivity is 0.1 Gs.
- The values are reported on the arrow corresponding to the direction of the magnetic field

**PN: QMC-CRYOTEE-0.218SMA-FMF**

**Description:** Cryogenic Bias Tee

**Comments:** The field of the device is below the 0.1Gs

