

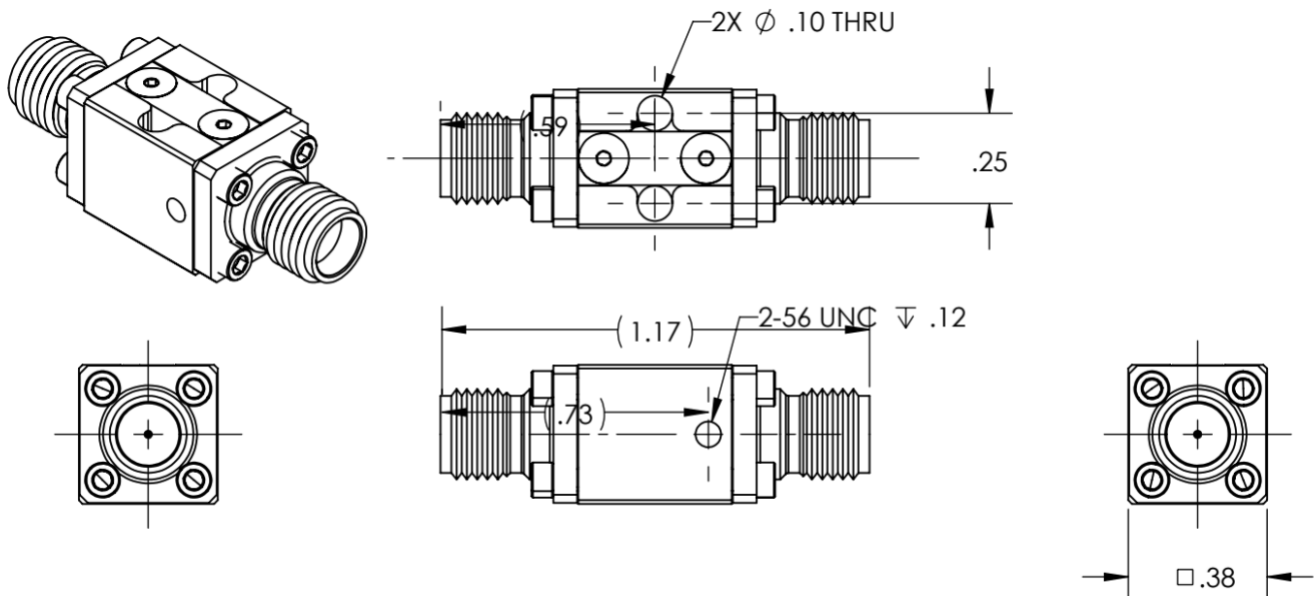

Specifications:

- Crystalline Quartz Cryogenic Attenuator
- Non-Magnetic
- Capable of operation at 10 mK
- Attenuation: 0 dB
- Frequency: DC to 18 GHz
- Return Loss: -23 dB typical
- Connectors: SMA F on Both Sides
- Max Power: 100 mW
- NiCr on crystalline 5 mil quartz
- Non-superconducting microstrip pad
- Stackable mechanical design
- Housing: Gold Plated OFHC Copper
- All connectors are field replaceable and swappable



Measured Data (typical)

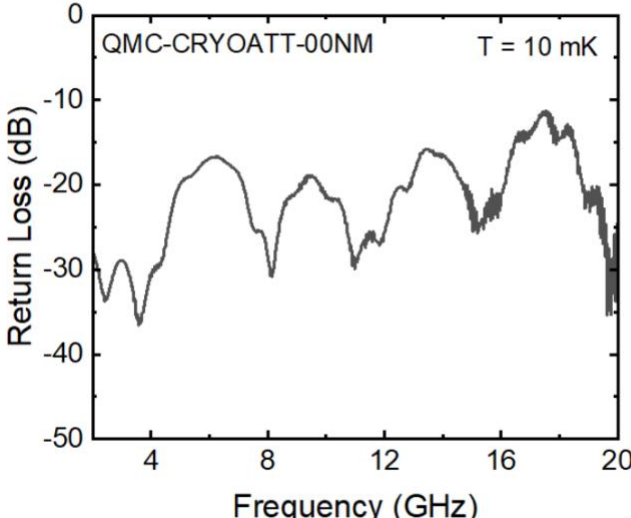
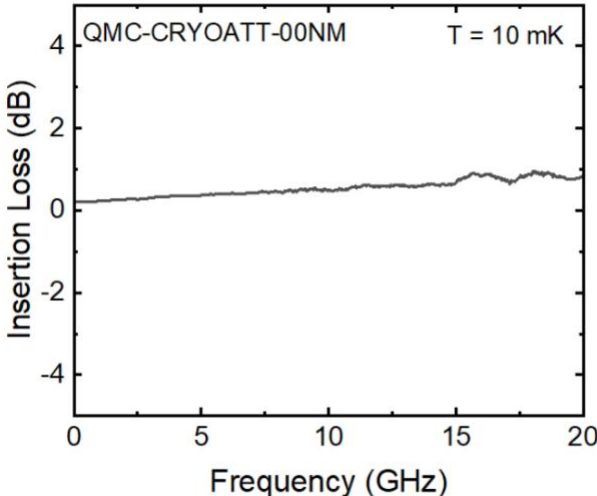
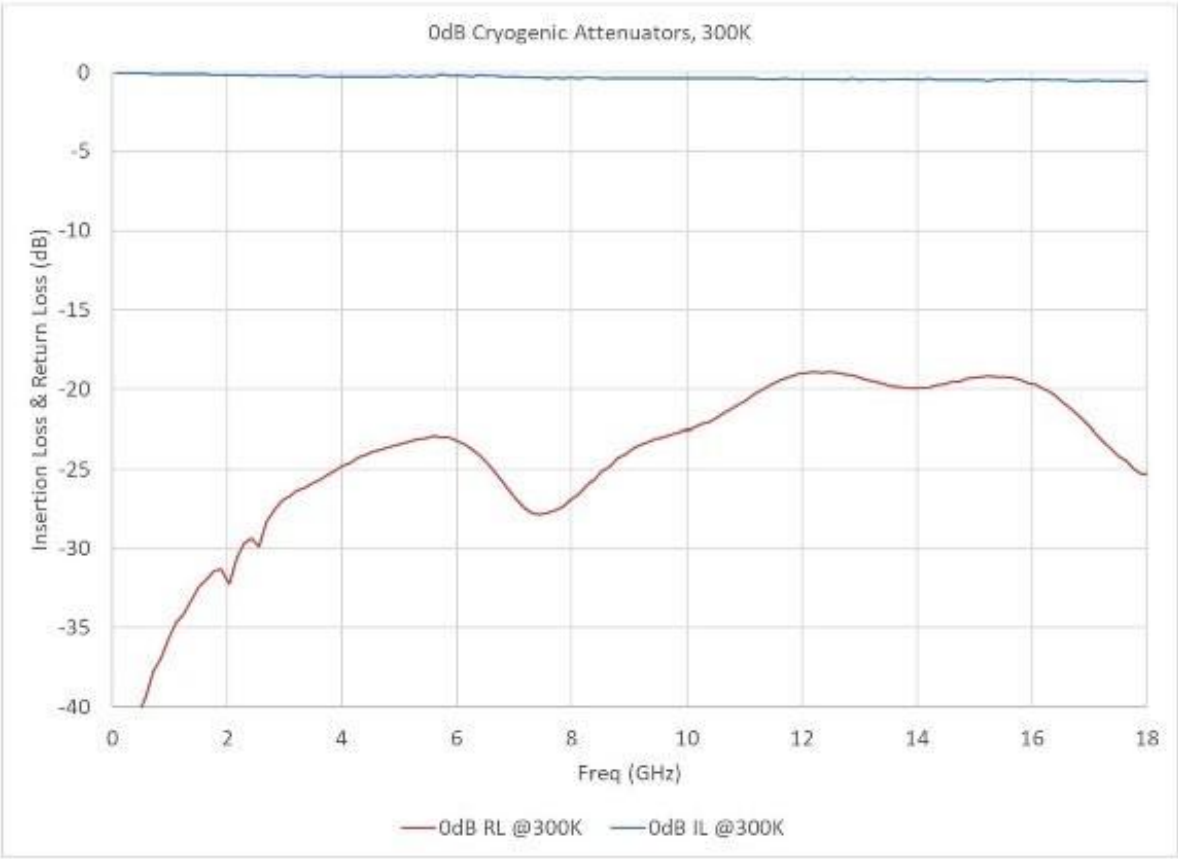

### Magnetism Test information:

- Before the measurement, the devices are put in proximity (below 1cm) to a magnet for about 5 seconds, to induce magnetization of eventual magnetic material.
- The magnetic field is measured over the surface of the device and along different axis. The distance between probe and device is below 1cm. The values reported in the picture is the maximum detected.
- All the measurements are in Gauss [Gs]
- The measurements have been done with a TD8620 magnetometer. Sensitivity is 0.1 Gs.
- The values are reported on the arrow corresponding to the direction of the magnetic field

**Part Number: QMC-CRYOATTF-00NM**

**Description:** 0 dB Cryogenic Non-Magnetic Attenuator

**Comments:** The Field of the device is below the 0.1 Gs

