



Specifications:

- High Cut-Off Frequency Infrared Filter
- Insertion loss less than 1.8 dB at 10 GHz @ 4K (typical)
- Return loss up to 12 GHz better than 15 dB (typical)
- Based on magnetically loaded dielectric absorber
- Eccosorb CR 110
- Impedance: 50 Ω
- Capable of operation at 10 mK
- Connectors: SMA F on both sides
- Housing Gold Plated OFHC Copper
- Length: 1.92 inches



Typical Frequency Response:

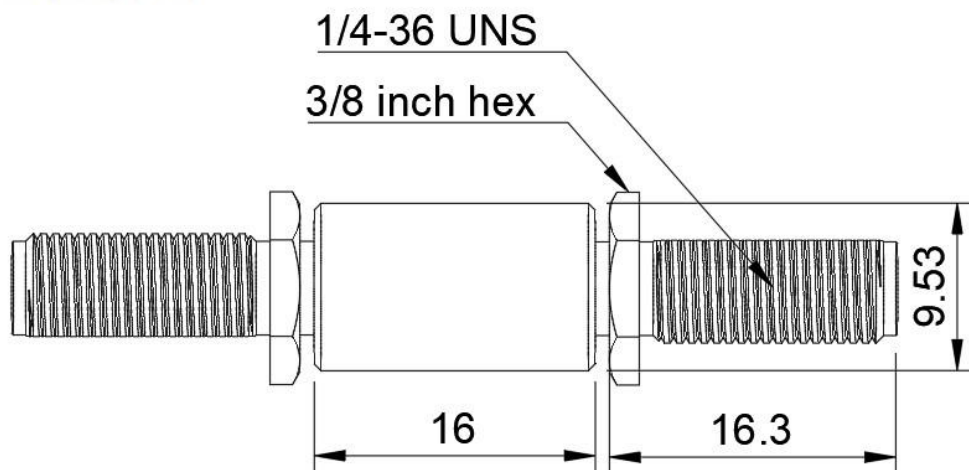
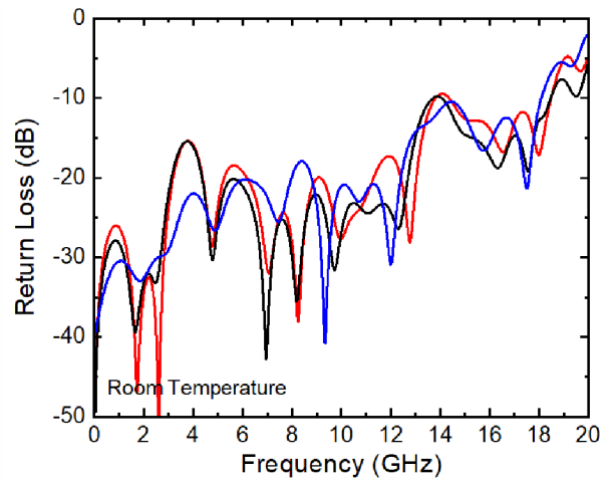
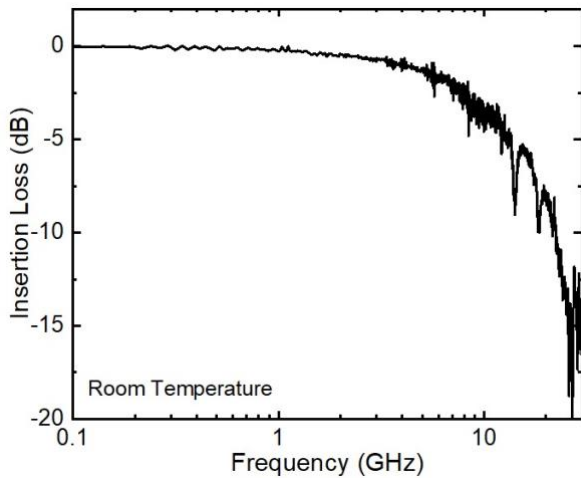

Made in the USA

✉ Sales@QuantumMicrowave.com

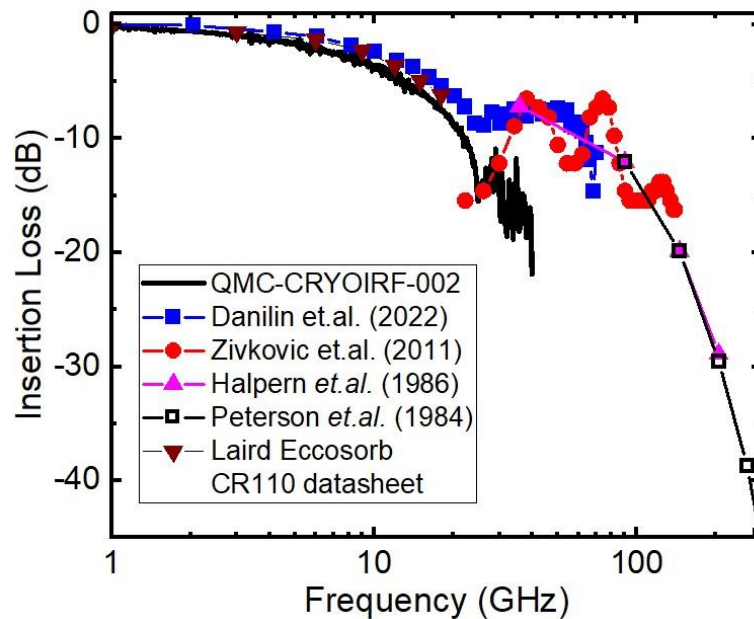

Insertion loss of QMC-CRYOIRF-002 filter (solid black line) plotted with insertion loss data derived from measured absorption of Eccosorb CR110 from literature [1-4] scaled to the dimensions of the QMC-CRYOIRF-002 filter. Above 300 GHz the absorption coefficient is expected to continue to vary with frequency as a power law [3].

1. Danilin, S., Barbosa, J., Farage, M. et al. Engineering the microwave to infrared noise photon flux for superconducting quantum systems. *EPJ Quantum Technol.* 9, 1 (2022).
2. Zivkovic I. and Murk A., Characterization of Magnetically Loaded Microwave Absorbers, *Progress in Electromagnetics Research B*, Vol. 33, 277-289 (2011).
3. Halpern M., Gush H.P., Wishnow E., and De Cosmo V., Far Infrared transmission of dielectrics at cryogenic and room temperatures: glass, Fluorogold, Eccosorb, Stycast, and various plastics, *Applied Optics* 25, 565 (1986).
4. Peterson J.B. and Richards P.L., A Cryogenic Blackbody for Millimeter Wavelengths, *Int. J. Infrared Millimeter Waves* 5, 1507 (1984).

Made in the USA

 Sales@QuantumMicrowave.com