

Wide-Band Josephson Parametric Amplifier Operating Guide

TM-2035
APPLICATION NOTE

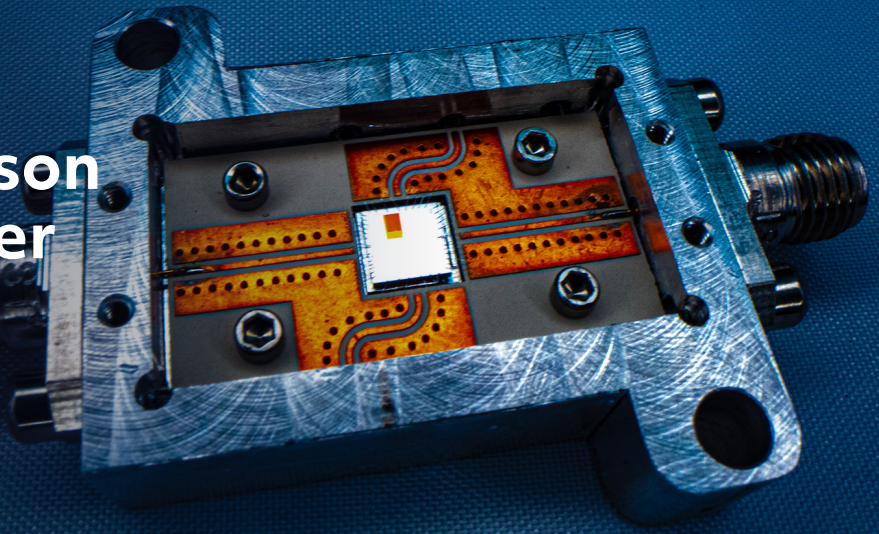

Contents

| | |
|--|-----|
| Introduction | 1 |
| Installation | 2 |
| Mechanical | 2 |
| Wiring | 2 |
| Attenuation and Filtering | 2 |
| Three Wave Mixing | 3 |
| Four Wave Mixing | 3 |
| Recommended Cryogenic Components | 3 |
| Room Temperature Components | 3-4 |
| DC Flux Bias Source | 4 |
| RF Pump Source | 4 |
| Operating the JPA | 4 |
| Flux Sweep | 4 |
| Pumping | 5 |
| Diagram | 5 |
| References | 6 |

Introduction

The RTX BBN Technologies' wideband Josephson parametric amplifier (JPA) is a cryogenic, superconducting near quantum limited amplifier suitable for quantum information science experiments and other microwave measurements that require an extremely low noise first stage amplifier. A wideband input matching network based on a coupled-line impedance transformer ensures wide bandwidth while maintaining high gain. RTX BBN has primarily used this amplifier for improving the measurement fidelity of superconducting transmon qubits. This Application Note contains recommendations for installing the JPA in a cryostat, wiring the JPA, and

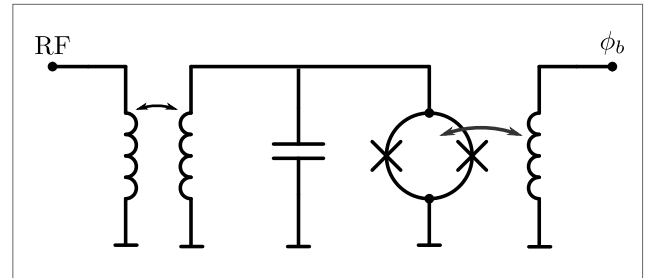

Figure 1: Schematic circuit diagram of the JPA amplifier.

a basic tune-up procedure that should allow the user to begin productive use of the device in their experiment. An extensive body of work on Josephson parametric amplifiers and related devices has been published in the scientific literature [1– 6], and we encourage those users to consult this body of work for details on the theory, design and operation of these devices.

While the JPA is primarily intended for end-users that are experienced in the techniques of cryogenic RF measurements and superconducting Josephson-based devices, we hope that this guide can offer a basic introduction that can help those less familiar with this type of measurement started with the device. We intend that this document will be updated frequently with user feedback, example use-cases and troubleshooting examples. Please contact jpa-support@rtx.com for support, feedback and suggestions.

Installation

This section provides recommendations for installing the JPA at the base temperature stage of a dilution refrigerator or other sub-1K cryostat. Please note that the JPA is based on conventional aluminum-aluminum oxide Josephson junction technology, and for optimal noise performance should be operated well below the critical temperature of Al. As is typical for superconducting devices, we strongly recommend operating the JPA inside magnetic shielding to prevent any degradation of performance or excess noise due to trapped flux from any background sources of magnetic fields. While we strive to reduce the amount of magnetic material in the JPA assembly, the device is not fully non-magnetic; please contact RTX BBN for further details and to discuss the potential availability of a fully non-magnetic option.

Mechanical

Detailed CAD assembly drawings of the JPA as well as a 3D STEP file of the JPA housing are available on request from RTX BBN. Mounting holes for #4 screws on a 1" grid spacing are provided. The housing is machined from aluminum, and should be clamped firmly to the cold stage of the cryostat in order to ensure good heat transfer from the package. The JPA should not be subjected to temperatures in excess of 60 °C as this may change or degrade the performance of the device in unpredictable ways.

Wiring

RF and DC connections to the device are through K connectors, which are mechanically compatible with SMA connectors. Care should be taken to not over-tighten these connections, and the use of a torque wrench is strongly recommended. The two screws clamping the connector flange to the package body should not be loosened, and should be inspected for tightness after repeated cool downs as they may loosen slightly over time due to thermal contraction and expansion. The low impedance of the Josephson junctions in the JPA make the device highly susceptible to ESD damage;

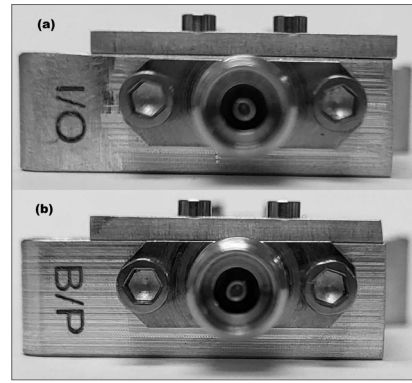

Figure 2: (a) RF input port of the JPA. (b) Flux bias port of the JPA.

the device is provided with two SMA shorting caps and these should be kept connected as long as is possible, and users handling the device should work in an ESD-safe manner (grounding straps, etc...).

The RF signal port of the JPA is marked on the package with I/O, and the flux bias port is marked with B/P, as shown in Figure 2.

As an impedance matched reflection amplifier, the performance of the JPA is highly dependent on the microwave environment it is embedded in. Good microwave hygiene should be followed to ensure that the JPA sees a 50Ω matched load with as few impedance discontinuities as possible: the number of connectors should be minimized, and **the distance between the JPA and circulator should be kept as short as possible**. Signs of a poor microwave environment include large ripples in the amplifier gain profile, standing waves in the measured S-parameters, and large (>10 dB) variations in pump power as the flux bias is changed.

Attenuation and Filtering

Please keep in mind the JPA's low saturation power when designing the microwave chain in your cryostat. The following attenuator configuration in a dry dilution refrigerator is used when measuring JPAs at RTX BBN for calibration purposes:

| Attenuator Configuration | | |
|--------------------------|-------------|-----------|
| Stage | Signal Line | Pump Line |
| 4K | 20 dB | 10 dB |
| Still (0.7K) | 6 dB | 6 dB |
| 0.1K | 3 dB | 3 dB |
| MXC (20mK) | 20 dB | 3 dB |

We do not have specific recommendations for filtering the signal or pump lines as these will vary based on the users' needs. Keep in mind that three wave mixing requires a pump near twice the amplified signal frequency.

Noise in the flux bias line will be detrimental to performance of the JPA. In addition to the filtering provided by the bias tee's choke inductor, we recommend a cold stage low pass filter with a MHz cutoff. The JPA should be biased through a resistor (typically in the $k\Omega$ range), preferably cold (for example at the 4K stage).

Three Wave Mixing

In three-wave mixing mode, both the DC flux bias (which tunes the resonant frequency) and the parametric drive (which generates amplification in the JPA) are applied to the flux bias port of the JPA. This port is coupled via a mutual inductance to the SQUID loop which provides the amplifier's nonlinear inductance. The input signal (ω_s) is routed to the gain port via a circulator. The pump tone (with $\omega_p \approx 2\omega_s$) and flux bias are combined with a cryogenic bias tee. An example wiring diagram of components at the cold stage is provided in Figure 3.

Four Wave Mixing

Wiring for four-wave mixing is broadly similar to three-wave mixing operation. In this mode, the pump tone is near the signal frequency (i.e. $\omega_s \approx \omega_p$) and is applied via a directional coupler to the input port of the JPA. An example wiring diagram of components at the cold stage is provided in Figure 4.

Recommended Cryogenic Components

This section details some cryogenic components that we have used successfully at RTX BBN while operating the JPA in a dilution refrigerator; we cannot guarantee the performance of these devices in any particular set-up. Contact the device manufacturers for more details. Users are encouraged to report to BBN the successful use of

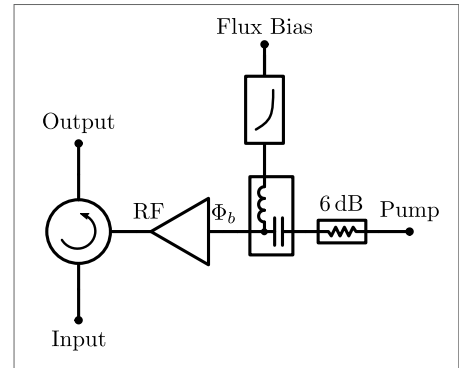

Figure 3: Cold-stage wiring diagram for driving the JPA in a three-wave mixing configuration.

commercially available components at cryogenic temperatures for the benefit of the JPA user community.

Circulators

- Low Noise Factory LNF-CIC4_8A and similar
- Quinstar QCY-G0400801 and similar

Directional Couplers

- QuantumMicrowave QMC-CRYOCOUPLER-20
- Krytar 120420

Bias tees

- QuantumMicrowave QMC-CRY TEE 0.218SMA
- MarkiMicrowave BT-0018
- Anritsu K251/V251

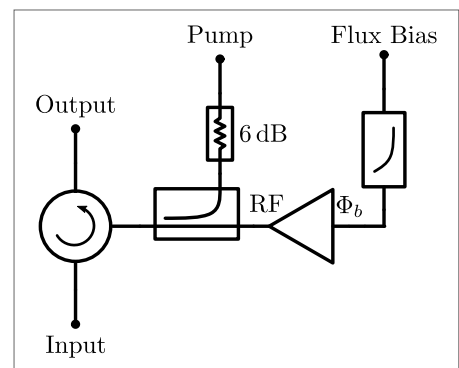

Figure 4: Cold-stage wiring diagram for driving the JPA in a four-wave mixing configuration.

Room Temperature Components

The primary room temperature needed for the JPA are a DC flux bias precision current source, and a microwave signal generator for providing

the parametric pump. As with the cryogenic components, we provide here a list of bias and pump sources we have used at RTX BBN; we encourage users to update us with information about other hardware that they have used with success.

DC Flux Bias Source

There are no particular requirements on the DC flux bias source beyond low noise and good stability and precision; common laboratory-grade precision current sources should suffice. We recommend a source with at least μA programmability. A selection of sources we have used in the lab at RTX BBN:

- Yokogawa GS200
- Keithley 2400 and 6400 series
- Stanford Research SIM928 (with suitable series bias resistor)

RF Pump Source

Similar to the flux bias source, there are no special requirements on the microwave signal generator used for the JPA pump beyond low phase noise and frequency stability and high enough output level to drive the JPA pump; the most important characteristic is good amplitude resolution (0.5 dB or better) as the JPA gain is highly sensitive to pump power. A selection of sources we have used in the lab at RTX BBN:

- Agilent N5183A and similar
- Holzworth HS9000 series
- DS Instruments SG22000PRO

Operating the JPA

We now provide a simplified guide to biasing the JPA for correct operation in three-wave mixing mode. Beyond the hardware mentioned above, a vector network analyzer (VNA) should be used to calibrate the device and set its operating parameters. The exact choice of operating parameters will depend on a user's experimental set-up and requirements. Please note also that

due to the nature of superconducting devices (for example, due to random flux offsets), the precise operating parameters may change from cooldown to cooldown. We strongly recommend recalibrating the JPA every time the cryostat is cycled to room temperature. As with the other sections of the document, we intend to continually update this guide with best practices, and welcome feedback and comments to make it more broadly useful.

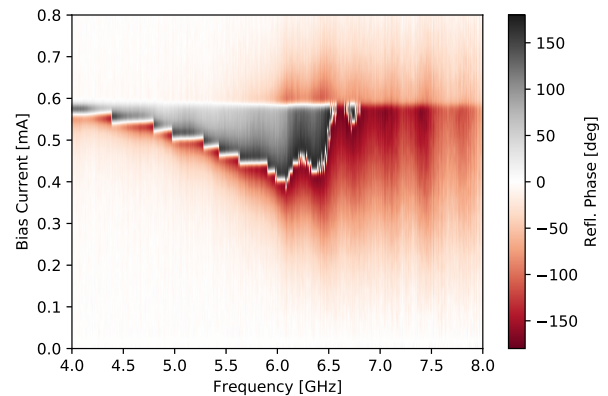

Figure 5: Bias sweep for JPA showing reflected phase normalized to zero-bias reflected phase to make as clear as possible the shifting resonance curve of the device. Applied signal power -124dBm

Flux Sweep

The first step in calibrating the JPA is to measure its RF response while sweeping the flux bias in order to determine the correct flux for the desired operating frequency. The flux bias has a periodicity of slightly less than 2mA. We recommend keeping the current through the flux bias port to less than $\pm 10\text{mA}$; more than this may drive the device into the normal state and could damage the Josephson junctions.

Due to the broadband nature of the RTX BBN JPA, the JPA resonance may not be clear when measuring the reflected amplitude of the signal; it is very sensitive to the RF environment of the JPA. The resonance will be most obvious in the reflected phase, as shown in Figure 5.

Pumping

Once the desired flux bias for an operating frequency has been set, the pump should be turned on and tuned to roughly twice the resonant frequency of the device as determined during the flux sweep. The pump power should be turned up slowly until gain begins to appear; the gain peak should quickly increase and its bandwidth broaden. In three-wave mixing mode, this should happen around -40dBm at the device. As the pump power continues to increase, side lobes and ripple will begin to appear; the gain profile may eventually narrow as the JPA approaches bifurcation. Some example gain curves are shown in Figure 6 for different pump frequencies and in Figure 7 for different pump powers; note that the pump power at the device is an estimation based on room temperature line loss measurements. Due to the sensitive dependence of the gain profile on the admittance of the environment at the JPA RF port, some experimentation will be required to find the optimal combination of bias current, pump power and pump frequency for a user's application needs and in a particular set up.

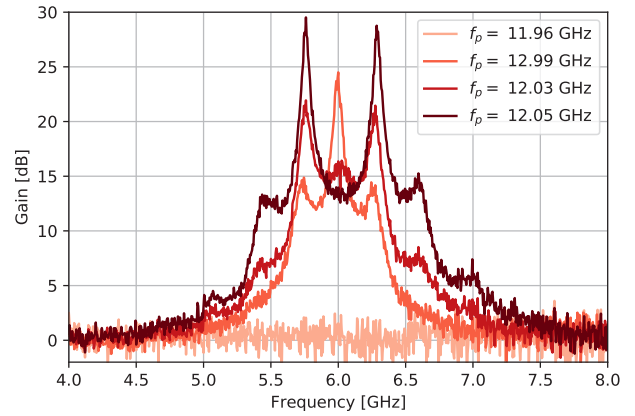

Figure 6: Gain curves for a JPA as a function of applied pump frequency in three-wave mixing mode. Current bias was set to 0.4mA , pump power -30dBm , and signal power -124dBm .

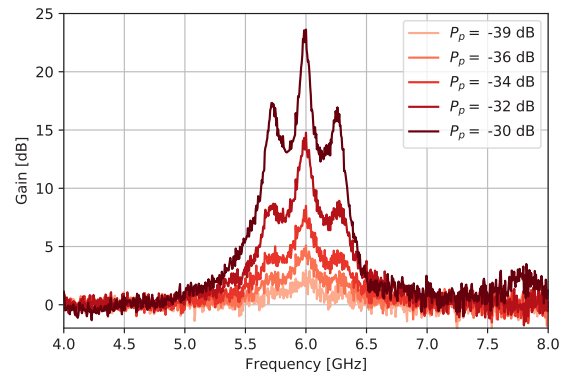
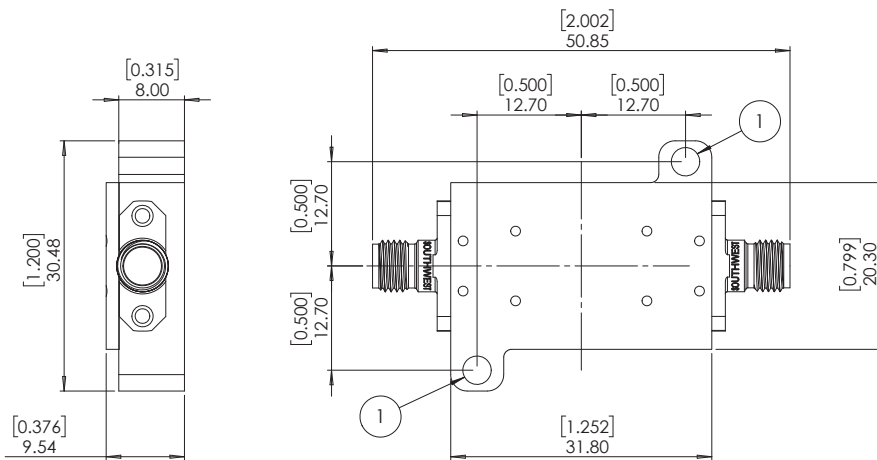

Figure 7: Gain curves for a JPA as a function of applied pump power in three-wave mixing mode. Current bias was set to 0.4mA , pump frequency 11.981GHz , and signal power -124dBm .

Mounting Dimensions



1. 4-40 Thru Hole for mounting screws

| Revision | Author | Changes |
|----------|------------|------------------|
| 0.9 | G. Ribeill | Initial revision |

References

1. B. Ho Eom, P. K. Day, H. G. LeDuc, and J. Zmuidzinas, "A wideband, low-noise superconducting amplifier with high dynamic range," *Nature Physics*, vol. 8, no. 8, pp. 623–627, 2012.
2. J. Mutus et al., "Design and characterization of a lumped element single-ended superconducting microwave parametric amplifier with on-chip flux bias line," *Applied Physics Letters*, vol. 103, no. 12, p. 122 602, 2013.
3. J. Y. Mutus et al., "Strong environmental coupling in a josephson parametric amplifier," *Applied Physics Letters*, vol. 104, no. 26, p. 263 513, 2014.
4. T. Roy et al., "Broadband parametric amplification with impedance engineering: Beyond the gain-bandwidth product," *Applied Physics Letters*, vol. 107, no. 26, p. 262 601, 2015.
5. J. Aumentado, "Superconducting parametric amplifiers: The state of the art in josephson parametric amplifiers," *IEEE Microwave Magazine*, vol. 21, no. 8, pp. 45–59, 2020.
6. J. Grebel et al., "Flux-pumped impedance-engineered broadband josephson parametric amplifier," *Applied Physics Letters*, vol. 118, no. 14, p. 142 601, 2021.

Contact

RTX BBN Technologies
10 Moulton Street
Cambridge, MA 02138
617-873-4JPA

© 2024 RTX BBN Technologies. All rights reserved. Trademarks and registered trademarks are the property of their respective owners.

jpa-support@rtx.com
www.bbn.com/jpa

